



# T0010507 AIR WALKER WITH HAND BIKE INCLUSIVE

T0010507 AIR WALKER WITH HAND BIKE INCLUSIVE

## VISTA TRIDIMENSIONALE

THREE-DIMENSIONAL VIEW

SCHEDA TECNICA (TECHNICAL DATA SHEET)

ART. T0010507

06-06-2024

SCALA (SCALE)

LE MISURE SONO ESPRESSE IN MM. (MEASUREMENTS ARE EXPRESSED IN MM.)



**TIEGI SRL**  
VIA BENEDETTO CROCE 7,  
Z.I. "CONDOTTI BARDINI",  
31058 SUSEGANA (TV)  
0438-460519

FOGLIO 1 DI 5

# PIANTA (PLAN)

5080

3060

450

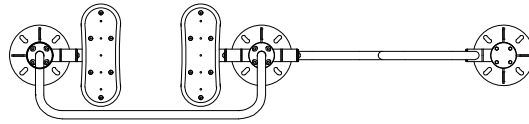

2080

AREA DI SICUREZZA (SECURITY AREA) 16 MQ

SCHEDA TECNICA (TECHNICAL DATA SHEET)

ART. T0010507

06-06-2024

SCALA (SCALE) 1:30

LE MISURE SONO ESPRESSE IN MM. (MEASUREMENTS ARE EXPRESSED IN MM.)



**TIEGI SRL**  
VIA BENEDETTO CROCE 7,  
Z.I. "CONDOTTI BARDINI",  
31058 SUSEGANA (TV)  
0438-460519

FOGLIO 2 DI 5



**ALTEZZA DI CADUTA MAX.**  
(MAX. FALL HEIGHT): <60 cm



**INGOMBRO (OVERALL DIMENSION)**  
208 cm X 45 cm X 126 cm H.



**NUMERO UTILIZZATORI 2**  
(MAX N. OF SIMULTANEOUS USERS)



**AREA DI SICUREZZA (SECURITY AREA)**  
306 cm X 508 cm



**SUP. ANTITRAUMA CONSIGLIATA**  
(RECOMMENDED SAFETY SURFACING AREA)  
16 MQ.



**ALTEZZO D'USO (HEIGHT USE)**  
>140 cm

**SCHEDA TECNICA (TECHNICAL DATA SHEET)**

**ART. T0010507**

06-06-2024

SCALA (SCALE)

LE MISURE SONO ESPRESSE IN MM. (MEASUREMENTS ARE EXPRESSED IN MM.)



**TIEGI SRL**  
VIA BENEDETTO CROCE 7,  
Z.I. "CONDOTTI BARDINI",  
31058 SUSEGANA (TV)  
0438-460519

FOGLIO 3 DI 5



**TUBI IN METALLO CURVATI. PROCESSO DI VERNICIATURA PER CATAFORESI, PRIMER E VERNICIATURA TERMOINDURENTE 180°C**

*(CURVED METAL TUBES. CATAPHORESIS, PRIMER AND 180°C THERMOSETTING PAINTING PROCESS APPLIED)*



**PIASTRE IN METALLO CON PROCESSO DI VERNICIATURA DI CATAFORESI, PRIMER E VERNICIATURA TERMOINDURENTE 180°C**

*(METAL PLATES WITH CATAPHORESIS, PRIMER AND 180°C THERMOSETTING PAINT PROCESS APPLIED)*

**L'ATTREZZO È PROVVISORIO DI QR CODE PER LA VISIONE DI VIDEO ESPLICATIVO D'USO** *(THE EQUIPMENT IS PROVIDED WITH A QR CODE, DISPLAYING AN EXPLANATORY VIDEO OF THE EXERCISE)*

**TUTTI GLI ELEMENTI DI FISSAGGIO, VITI, DADI, RONDELLE ECC. SONO IN ACCIAIO INOX**

*(ALL FASTENERS, SCREWS, NUTS, WASHERS, ETC. ARE MADE OF STAINLESS STEEL)*

**SCHEMA TECNICA (TECHNICAL DATA SHEET)**

**ART. T0010507**

**06-06-2024**

**SCALA (SCALE)**

**LE MISURE SONO ESPRESSE IN MM. (MEASUREMENTS ARE EXPRESSED IN MM.)**



**TIEGI SRL**  
VIA BENEDETTO CROCE 7,  
Z.I. "CONDOTTI BARDINI",  
31058 SUSEGANA (TV)  
0438-460519

**FOGLIO 4 DI 5**

VISTA FRONTALE  
(FRONTAL VIEW)

ALTEZZA MASSIMA DI  
CADUTA LIBERA  
(MAXIMUM HEIGHT OF THE  
FREE FALL): < 60 cm

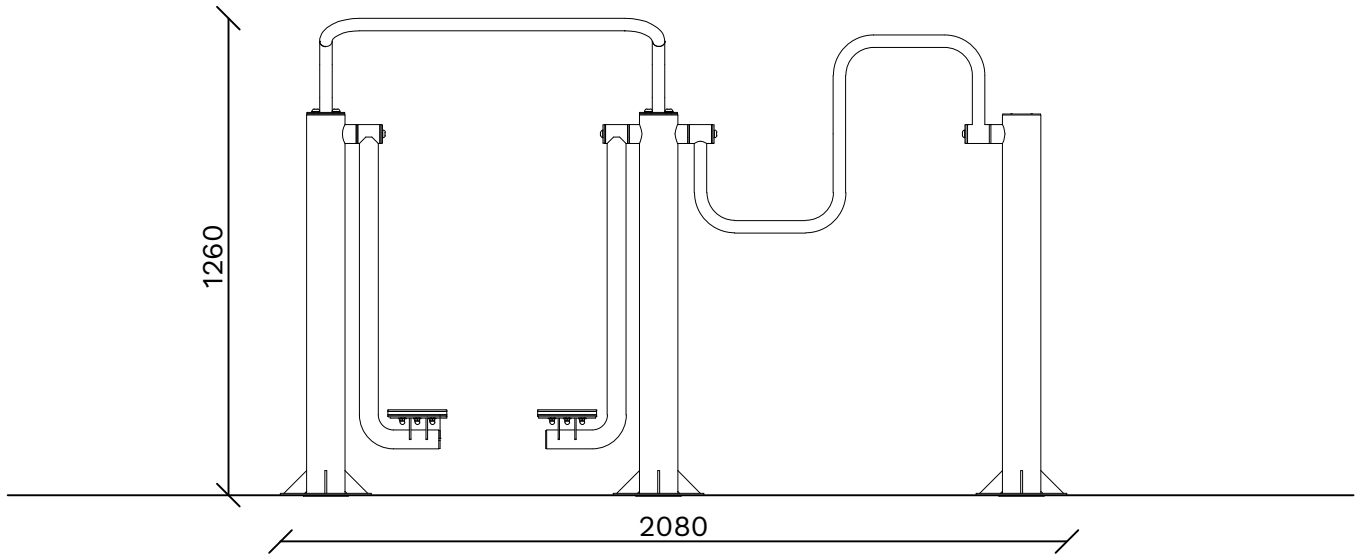

VISTA LATERALE  
(LATERAL VIEW)

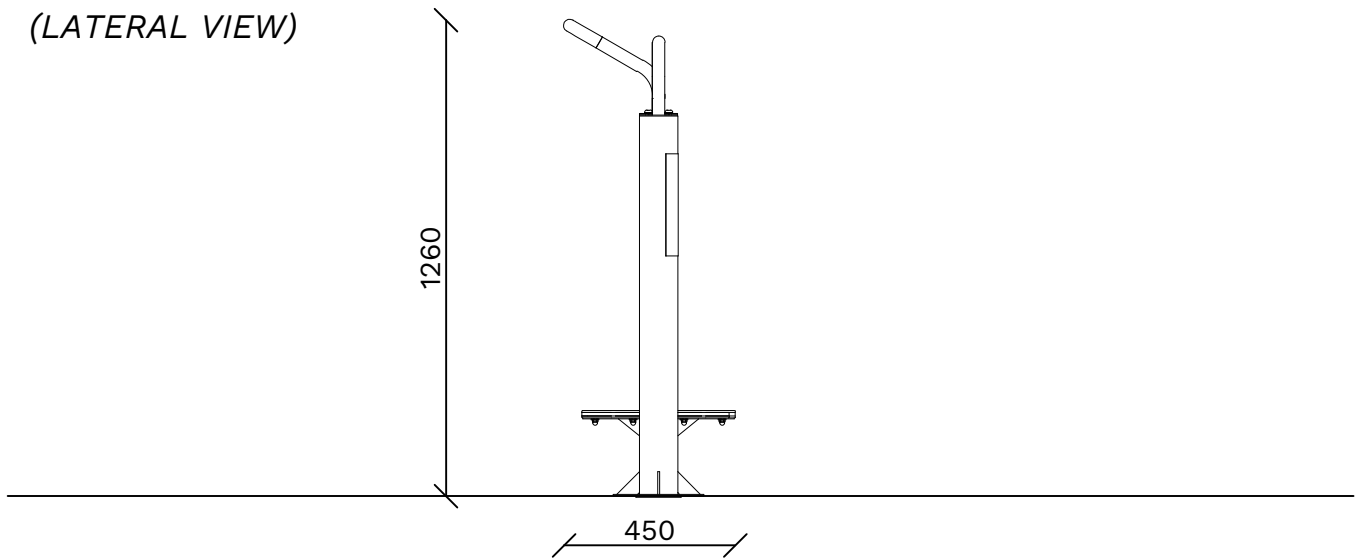

INGOMBRO MAX (OVERALL DIMENSIONS)

SCHEDA TECNICA (TECHNICAL DATA SHEET)

ART. T0010507      06-06-2024      SCALA (SCALE) 1:20

LE MISURE SONO ESPRESSE IN MM. (MEASUREMENTS ARE EXPRESSED IN MM.)



TIEGI SRL  
VIA BENEDETTO CROCE 7,  
Z.I. "CONDOTTI BARDINI",  
31058 SUSEGANA (TV)  
0438-460519

FOGLIO 5 DI 5